

**KATALOG
CATALOGUE
CATALOGO
CATÁLOGUE
CATÁLOGO**

GRINDER

2018

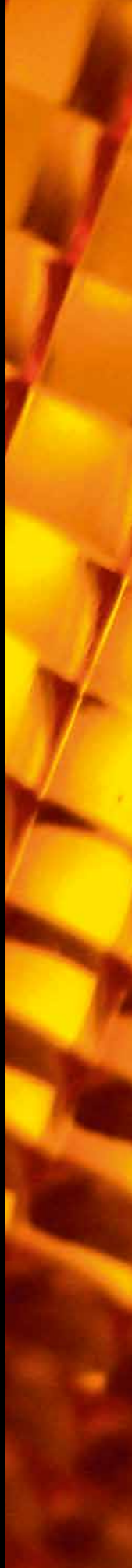

Near Dark
SMOKING PARAPHERNALIA

Piktogramme | Pictogram | Pittogrammi | Pictogramme | Pictogramas

	Verpackungseinheit Packaging Unit Unità d'imballaggio Unité de conditionnement Unidad de embalaje
	Größe Size Misura Taille Tamaño
	Breite Width Ampiezza Largeur Ancho
	Höhe Height Altezza Hauteur Altura
	Maße Dimensions Dimensioni Dimensions Medidas
	Länge Length Lunghezza Longueur Largo
	Durchmesser Diameter Diametro Diamètre Diámetro
	Ansatz Angle Base Base Ángulo
	Aroma Aroma Aroma Arôme Aroma
	Aufbau Setup Montaggio Montage Estructura
	Diffuser Diffuser Diffusore Diffuseur Difusor
	Farbe Color Colori Coloris Color
	ICE Ice notches (Ice) Ice piercing (ghiaccio) Indentations (glace) Espina (hielo)
	Kickloch Kickhole Valvola di rilascio Carburateur Agujero de inhalación
	Wandstärke Wall Thickness Spessore pareti Épaisseur de paroi Grosor de paredes
	Material Material Materiale Matériau Material
	Messbereich Measurement Campo di misura Plage de mesure Área de medida
	Motiv/Design Design Motivo/Design Motif / design Motivo/diseño
	Öl Oil Olio Huile Aceite/bho
	Perkolator Percolator Percolatore Percolateur Percolador
	Power Power Potenza Puissance Potencia
	Print Print Stampa Impression Estampado
	Qualität Quality Qualità Qualité Calidad
	Schliff Grind Levigatura Section polie Filo
	System System Sistema Système Sistema
	Zubehör Supplies Accessori Accessoires Accesorios
	Info Info Informazioni Info Información
	Sonstiges Other Altro Autres Otros

Farben | Colours | Colori | Coloris | Colores

	25 = weiß white bianco blanc blanco
	26 = gelb yellow giallo jaune amarillo
	27 = gold golden oro doré oro
	28 = rot red rosso rouge rojo
	29 = blau blue blu bleu azul
	30 = hellblau light blue azzurro bleu ciel celeste, azul claro
	31 = aquamarin aquamarine acqua marina turquoise aguamarina
	32 = transparent transparent trasparente transparent transparente
	33 = violett violet viola violet violeta, morado
	34 = rosa pink rosa rose rosa
	35 = schwarz black nero noir negro
	36 = grau/titan grey/titanium grigio/titanio gris/titane gris/titanio
	37 = dunkelgrün dark green verde scuro vert foncé verde oscuro
	38 = hellgrün light green verde chiaro vert clair verde claro
	39 = silber silver argento argent plata
	40 = orange orange arancione orange naranja
	41 = braun brown marrone marron marrón
	42 = chrom chrome cromato chrome cromo
	43 = bronze bronze bronzo bronze bronce
	44 = beige beige beige beige beis
	45 = amber amber ambra ambre ámbar
	46 = aubergine aubergine viola scuro aubergine berenjena
	47 = rasta rasta rasta rasta rasta

Farben und Maße können abweichen | Colours and sizes can vary | Colori e dimensioni possono variare | Coloris et dimensions peuvent varier | color y medidas pueden variar

Inhalt

- 09 Metallmühlen
- 43 Holzmühlen
- 48 Steinmühlen
- 49 Acrylmühlen
- 55 Messer und Zubehör

Contenuto

- 09 Grinder in metallo
- 43 Grinder in legno
- 48 Grinder in pietra
- 49 Grinder in materiale acrilico
- 55 Coltelli e accessori

Contenido

- 09 Grinder de metal
- 43 Grinder de madera
- 48 Grinder de piedra
- 49 Grinder de acrílico
- 55 Cuchillos y accesorios

Content

- 09 Metal Grinder
- 43 Wooden Grinder
- 48 Stone Grinder
- 49 Acrylic Grinder
- 55 Knives and Accessories

Table des matières

- 09 Grinder en métal
- 43 Grinder en bois
- 48 Grinder en pierre
- 49 Grinder en acrylique
- 55 Couteaux et accessoires

Neuheiten, Sonderangebote, Restposten immer aktuell unter www.neardark.de | **New Products, Deals, Remainder always up-to date at www.neardark.de** | Novità, offerte speciali e posti residui all'indirizzo www.neardark.de | **Dernières nouveautés, promotions et fins de série sur le site www.neardark.de** | Novedades, ofertas especiales y remanentes pueden encontrarse en www.neardark.de

Grinder



Grinder, zu Deutsch Mahlwerk, ist der in den USA geprägte Begriff für Mühlen zur Zerkleinerung von Hanfprodukten wie Haschisch oder Marihuana. Erstmals tauchten sie in Deutschland in den 90er Jahren auf. Die erste mir bekannte Mühle war der zweiteilige Holzgrinder mit eingebauten Stiften der Marke Sweatleaf. Grinders werden aus den unterschiedlichsten Materialien hergestellt wie z.B.: Aluminium, Edelstahl, Acryl, Holz und Speckstein. Es gibt sie in den verschiedensten Ausführungen wie 2-, 4- oder mehrteilig, mit Kurbel, elektrisch oder mit Federzug. Zur extra Gewinnung von Pollenmaterial aus Marihuana haben mehrteilige Grinders Siebe eingebaut, manche sogar auch mit unterschiedlichen Maschenweiten. Bei verschiedenen Siebstärken in einem Grinder entstehen unterschiedliche Pollenqualitäten: Je feiner das Sieb, desto potenter der Pollen. Auch durch die Anordnung und die Form der Zähne unterscheiden sich die Mühlen. Je nach Anzahl und Form der Mahlzähne wird das Material gröber oder feiner zerkleinert. Grinders mit Stiften werden zur Zerkleinerung von Marihuana und Grinders mit Zähnen zur Zerkleinerung von Haschisch (hart, nicht ölig) und Marihuana verwendet.

Ein wichtiger Punkt bei den Grindern ist das Material, aus dem die Mühlen hergestellt sind. Es gibt heftige Diskussionen darüber, ob der Abrieb der Grinders in der Rauchmischung gesundheitsgefährdend ist. Es ist sicher, dass ein Grinder aus hartem Material weniger Abrieb hat, als einer, der aus weichem Material gefertigt wurde. Die Farben werden elektrolytisch aufgetragen und härten das Aluminium zusätzlich. Da die Farben gesundheitlich nicht unbedenklich sind, gibt es auch Grinders die nur äußerlich farblich eloxiert sind, im Mahlwerk dagegen nur materialfarben sind. Vorzuziehen sind aus meiner Sicht Grinders aus Holz oder Metallen mit gehärtetem Überzug (hard anodized), sowie solche aus Edelstahl.

Bei der neuesten Generation mehrteiliger Grinders lassen sich auch die unter den Zähnen befindlichen Lochscheiben, durch die das Material nach dem Zerkleinern fällt, auswechseln. Das ermöglicht es, genau den richtigen Grad an Zerkleinerung zu bestimmen, den man für die verschiedenen Genussmethoden braucht, z.B. gröberes Gras zum Drehen von Joints, feiner gemahlenes zum Vaporisieren.

Haschisch lässt sich in den meisten Mühlen mit Zähnen ebenfalls zerkleinern. Dafür sollte es möglichst kalt und nicht zu ölig (schmierig) sein. Am besten wird es im Kühlschrank aufbewahrt. Wer seine Rauchmischung mit Tabak anreichert, kann diesen auch sofort mit in den Grinder geben und alles zusammen vermahlen. Diese Mischung ist besser durchmischt als mit der Handmethode und brennt sauberer ab. Alle Mühlen, die nicht aus Holz sind, lassen sich mit alkoholhaltigen Reinigern oder speziellen Grinder-Reinigern einfach säubern. Restrückstände können rausgekratzt oder mit harten Borsten einer Bürste entfernt werden. Holzmühlen werden einfach nur ausgekratzt.

Ernst Meerbeck
Gründer und Inhaber von Near Dark

Grinders



Grinder is the term shaped in the USA for querns for mincing hemp products like hashish and marihuana. Initially, they appeared in Germany during the 90s. The first grinder I got aware of was the two-part wooden grinder with integrated pins of the brand Sweatleaf. The grinders are made of the most diverse materials like for example aluminium, stainless steel, acrylic, wood or soapstone. They come in 2-, 4- or more parts, with crank, spring balancer or electrically driven. For the extraction of pollen from marihuana, multipart grinders have integrated screens, some even come with different mesh widths. Different mesh widths make for different quality of pollen: the finer the screen, the more potent the pollen. Grinders also vary respective arrangement and form of the teeth. Depending on number and form of the teeth, the material is minced more fine or coarse. Grinders with pins are taken for shredding marihuana and grinders with teeth for shredding hashish (hard, not oily) and marihuana.

An important point is the material grinders are made of. There are fervid discussions if the abrasion of the grinder in the smoking mixture is a health risk. It is sure that a grinder made of hard material has less abrasion than one made of soft material. The colours are applied electrolytically and harden the aluminium additionally. Since the colours are not harmless, there are grinders which are anodized only outside while the grinding chamber stays uncoloured. In my opinion, grinders made of wood or metal with hardened coating (hard-anodized) as well as of stainless steel are to be preferred.

The latest generation of multipart grinders has replaceable punched discs underneath the grinding teeth through which the material falls after shredding. This enables to find just the right degree of shredding needed for the various indulging methods, for example coarse grass for joints, fine grass for vaporization.

Hashish can also be minced in most grinders with teeth. For this purpose, it should be as cold as possible and not too oily (greasy). It is best stored in the refrigerator. Those who enrich their smoking mixture with tobacco can add the tobacco at once to the grinder and grind together. The mixture is better mixed than when stirred by hand and burns down more smoothly.

All grinders which are not made of wood can easily be cleaned with alcohol-containing cleaners or special grinder cleaners. Remains can be removed with a scraper or with the hard bristles of a brush. Wooden grinders are simply scraped out.

Ernst Meerbeck
Founder and Owner of Near Dark

Grinder



Il termine "grinder" significa in italiano molino ed è comunemente usato negli USA per designare i macina erba utilizzati per sminuzzare i prodotti a base di canapa come l'hashish o la marijuana. Questi attrezzi hanno fatto la loro prima apparizione in Germania negli anni '90. Il primo macina erba di mia conoscenza è un grinder in legno a due pezzi con piccoli chiodi incorporati del marchio Sweatleaf. I grinder sono realizzati nei materiali più diversi, come ad es. alluminio, acciaio inossidabile, acrilico, legno e steatite. Sono disponibili in tanti modelli differenti a due, quattro o più parti, a manovella, a funzionamento elettrico o con meccanismo a molla. Per recuperare il polline dalla marijuana i grinder a più parti sono muniti di un setaccio incorporato, alcuni addirittura con ampiezze di maglia diverse. La qualità del polline dipende dallo spessore delle maglie del setaccio: più fine è il setaccio, più concentrato il polline. I grinder si differenziano anche per la disposizione e per la forma dei dentini. A seconda del numero e della forma dei dentini il materiale viene tritato con maggiore o minore finezza. I grinder con i chiodi sono utilizzati per tritare la marijuana, mentre quelli con i dentini sono usati per sminuzzare sia hashish (duro, non oleoso) che marijuana.

È di grande importanza il materiale con cui vengono realizzati i grinder. Attualmente c'è un dibattito aperto sui possibili danni per la salute causati dalla presenza di particelle dovute ad abrasione. Certo è che un grinder in materiale duro produce meno abrasione rispetto a uno realizzato in materiale più morbido. I colori sono applicati con procedimento elettrolitico e rafforzano in misura ancora maggiore la durezza dell'alluminio. Dato che i colori possono essere dannosi per la salute esistono anche grinder colorati per anodizzazione soltanto all'esterno mentre l'interno ha invece il colore del materiale con cui è stato realizzato. A mio avviso è meglio optare per grinder in legno o in metallo con rivestimento duro (anodizzazione dura) o per quelli in acciaio inossidabile.

I grinder di nuova generazione a più parti sono dotati di griglie perforate intercambiabili situate sotto ai dentini attraverso le quali passa il materiale tritato. Questo consente di determinare con precisione il grado di sminuzzamento di cui si ha bisogno per le diverse esigenze, ad es. erba dal taglio più grossolano per gli spinelli, tritata più finemente per il vaporizzatore.

Anche l'hashish può essere sminuzzato nella maggior parte dei grinder con i dentini. A questo scopo deve essere possibilmente freddo e non troppo oleoso (grasso). Conservare preferibilmente in frigorifero. Chi arricchisce la propria miscela con tabacco può aggiungerlo direttamente nel grinder e macinare tutto insieme; ne risulterà una miscela più omogenea rispetto al metodo manuale e una combustione più uniforme.

Tutti i grinder che non sono stati realizzati in legno possono essere puliti semplicemente con detergenti a base di alcool oppure con detergenti specifici per grinder. Per eliminare i residui di materiale grattare o utilizzare una spazzola con setole dure. Per pulire i grinder in legno basta semplicemente grattare le parti che presentano impurità.

Ernst Meerbeck
Fondatore e proprietario di Near Dark

Grinder



Le terme de « grinder », broyeur en français, est communément utilisé aux États-Unis pour désigner les moulins à herbe servant à hacher des produits à base de chanvre, tels que le haschisch ou la marijuana. Ces appareils sont apparus pour la première fois en Allemagne dans les années 90. Le premier broyeur que j'ai eu entre les mains était un grinder en bois deux pièces avec dents intégrées de la marque Sweatleaf. Les grinders sont fabriqués dans les matériaux les plus divers, tels que par ex. : aluminium, acier inoxydable, bois et stéatite. Ils existent en plusieurs versions, à deux, quatre ou plusieurs parties, à fonctionnement électrique, à manivelle ou à ressort. Afin de récupérer le pollen de la marijuana, les grinders à plusieurs parties sont munis de tamis, dont certains avec différentes tailles de maille. La qualité du pollen dépend de la taille des mailles : Plus le tamis est fin, plus le pollen est concentré. Les broyeurs se différencient également par l'agencement et la forme des dents. La matière est hachée plus grossièrement ou plus finement en fonction du nombre et de la forme des dents. Les grinders à clous sont utilisés pour le hachage de la marijuana, ceux à dents pour le broyage du haschisch (dur, non huileux) et de la marijuana.

Le matériau de fabrication joue un rôle important dans le choix d'un grinder. Un vif débat s'est ouvert quant aux risques potentiels pour la santé de la présence de particules d'usure des grinders dans le mélange à fumer. Il est certain qu'un grinder en matériau dur produit moins d'usure qu'un grinder en matériau souple. Les couleurs sont appliquées par électrolyse et renforcent de surcroît la dureté de l'aluminium. Les couleurs pouvant nuire à la santé, il existe des grinders colorés par anodisation uniquement sur l'extérieur, l'intérieur étant laissé dans le ton du matériau. À mon avis, il est préférable d'opter pour des grinders en bois ou en métal à revêtement dur (anodisation dure) ainsi qu'en acier inoxydable.

Les grinders de la nouvelle génération sont dotés de grilles perforées interchangeables, placées sous les dents, et au travers desquelles passe la matière broyée. Cela permet de choisir le degré de broyage adéquat selon le but recherché, par ex. herbe grossièrement hachée pour rouler des joints ou finement moulue pour vaporisateur.

Le haschisch peut être broyé dans les plupart des moulins à dents. À cet effet, il doit être le plus froid possible et pas trop huileux (gras). À conserver de préférence au réfrigérateur. Au cas où le mélange à fumer serait additionné de tabac, mettre ce dernier également dans le grinder et broyer le tout. Le mélange obtenu est plus homogène que fait à la main et assure une combustion plus uniforme.

Tous les moulins, qui ne sont pas en bois, peuvent être facilement nettoyés avec des détergents à base d'alcool ou des détergents spéciaux pour grinders. Gratter ou utiliser une brosse à poils durs pour éliminer les résidus. Dans le cas des moulins en bois, il suffit de gratter les endroits concernés.

Ernst Meerbeck
Fondateur et propriétaire de Near Dark

Grinder



Grinder, "Mahlwerk" en alemán, es en los EE.UU. una expresión para molinos de trituración de productos de cáñamo, como el hachís y la marihuana. Por primera vez aparecieron en los años 90 en Alemania. El primer grinder que conocí era el grinder de madera de dos piezas con pins de la marca Sweatleaf. Los grinders están hechos de diferentes materiales, como por ejemplo: de aluminio, acero inoxidable, acrílico, madera y piedra. Están disponibles en varios diseños, como de 2, 4 o más partes, con manivela, eléctricos o con equilibrador. Para la extracción adicional de polen algunos grinders tienen tamices integrados, algunos incluso con diferentes tamaños de malla. En diversos espesores de tamices pueden crear diferentes grados de polen: Cuanto más fino sea el tamiz, más potente será el polen. Los grinders también se distinguen por la colocación y forma de los dientes. Dependiendo del número y forma de los dientes, el material es más grueso o más fino. Grinders con pins son para moler la marihuana y grinders con dientes para moler hachís (duro, no aceitoso) y para el uso de marihuana.

Un punto importante en los grinders es el material del que están hechos. Existe un debate sobre si la abrasión del grinder es un peligro para la salud en la mezcla de fumar. Es cierto que un grinder hecho de material duro tiene menos abrasión que uno que fue hecho de un material blando. Los colores se aplican por electrólisis y endurecen el aluminio adicionalmente. Dado que los colores no son inofensivos para la salud, también existen grinders que solo tienen el color externo y que en el molino solo llevan el color del material. En mi opinión son preferibles los grinders de madera o metales con revestimiento curado (anodizado duro) y los de acero inoxidable.

En la última generación de grinders con múltiples partes también se puede reemplazar el disco de los dientes, a través del cual el material cae después de ser molido. Esto hace que sea posible determinar con precisión el grado correcto de trituración para los diferentes métodos de consumo, por ejemplo la hierba más gruesa para liar joints y la hierba más fina para vaporizar.

El hachís también se puede triturar bien con el grinder. Debería estar frío y no ser demasiado aceitoso (grasiento). Se debe almacenar en el refrigerador. El que enriquece su mezcla con tabaco, lo puede meter también en el grinder y mezclar todo junto en él. Esta mezcla es mejor que la que se mezcla a mano y quema mejor.

Todos los grinders que no son de madera se pueden limpiar con productos de limpieza a base de alcohol o limpiadores especiales para grinders. Los residuos incrustados pueden ser raspados o eliminados con cerdas duras de un cepillo. Los grinders de madera solo se deben raspar.

METALLMÜHLEN METAL GRINDER GRINDER IN METALLO GRINDER EN MÉTAL GRINDER DE METAL

Mühlen aus Metall, zwei-, drei-, vier- oder fünfteilig, sind nahezu unzerstörbar. Unsere Mühlen werden auf hochpräzisen CNC-Drehbänken mit geringer Toleranz gefertigt und drehen und drehen sich ... ein Leben lang.

Metal grinders, two-, three-, four- or five-part are almost indestructible. Our grinders are made on high-precision CNC-machines with low tolerance and they grind and grind and grind ... lifelong.

I grinder in metallo composti da due, tre, quattro o cinque parti sono praticamente indistruttibili. I nostri grinder sono prodotti su torni CNC di massima precisione e a minima tolleranza e ruotano, ruotano... per tutta la vita.

Les moulins en métal, en deux, trois, quatre ou cinq parties, sont pratiquement indestructibles. Nos moulins sont fabriqués sur des tours CNC de haute précision à faible tolérance et tournent, tournent... à vie.

Los grinders de metal, de dos, tres, cuatro o cinco piezas, son prácticamente indestructibles. Nuestros grinders se fabrican en tornos CNC de alta precisión, con baja tolerancia, y giran y giran ... toda una vida.

Ernst Meerbeck
Fundador y propietario de Near Dark

'Black Leaf' 'Steely Dan' Edelstahl-Grinder 'Black Leaf' 'Steely Dan' Stainless Steel Grinder

-  Edelstahl
Stainless Steel
-  Steely Dan, Black Leaf Logo
-  Diamantschliff Zähne
Diamond-cut Teeth
-  Reißverschlussstasche
Zip Bag

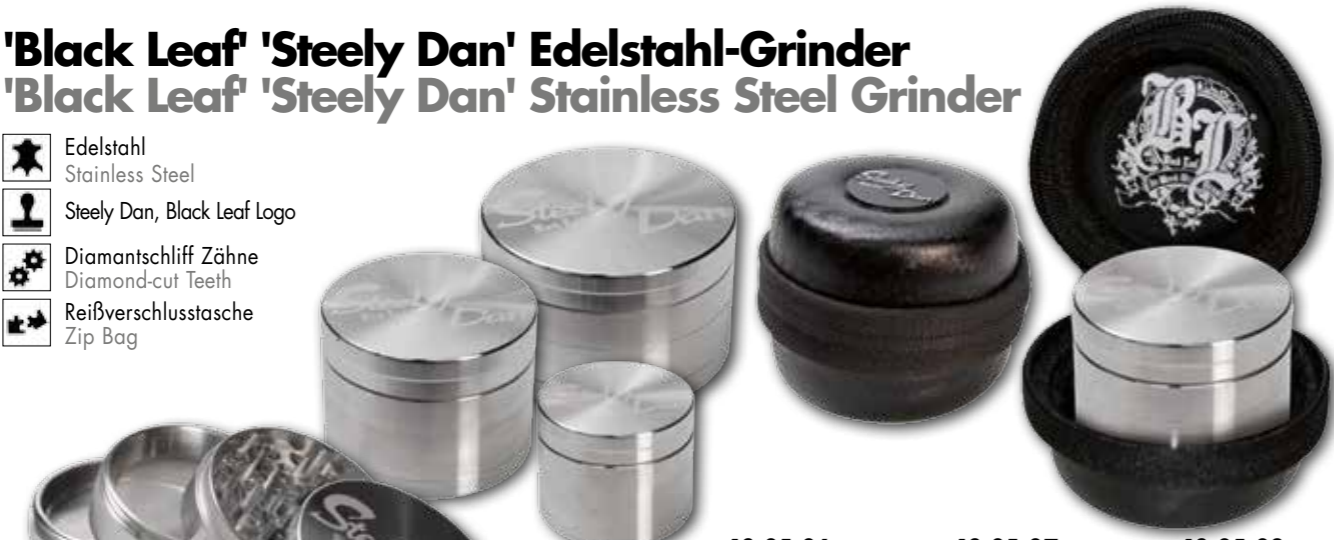

43 05 06	43 05 07	43 05 08
 4-tgl. 4-part	 4-tgl. 4-part	 4-tgl. 4-part
 38mm	 49mm	 59mm
 32mm	 37mm	 37mm

ABRIEBFREI - HÄLT EWIG!
ABRASION-FREE - VERY DURABLE!



43 05 09	43 05 10	43 05 11
 2-tgl. 2-part	 2-tgl. 2-part	 2-tgl. 2-part
 39mm	 49mm	 59mm
 15mm	 19mm	 19mm





'BL' Edelstahl-Grinder 'BL' Stainless Steel Grinder

-  Edelstahl | Stainless Steel
-  Silber | Silver
-  'BL'-Logo
-  Diamantschliff Zähne
Diamond-cut Teeth























43 05 03	43 05 04	43 05 05
 2-tgl. 2-part	 2-tgl. 2-part	 2-tgl. 2-part
 39mm	 49mm	 59mm
 15mm	 21mm	 22mm
43 05 00	43 05 01	43 05 02
 4-tgl. 4-part	 4-tgl. 4-part	 4-tgl. 4-part
 38mm	 49mm	 59mm
 33mm	 41mm	 42mm

'BL' Granite Grinder

-  Aluminium, hart anodisiert | Hard Anodized
-  Anthrazit | Anthracite
-  'BL' Granite-Logo oder/or 'BL' Premium-Logo
-  Diamantschliff Zähne
Diamond-cut Teeth









GEHÄRTETE OBERFLÄCHE - ABRIEBFREI!
HARDENED SURFACE - ABRASION-FREE!









43 02 70	43 02 71	43 02 72	43 02 73
 2-tgl. 2-part	 2-tgl. 2-part	 2-tgl. 2-part	 2-tgl. 2-part
 40mm	 50mm	 56mm	 63mm
 21mm	 21mm	 21mm	 21mm
43 02 74	43 02 75	43 02 76	
 4-tgl. 4-part	 4-tgl. 4-part	 4-tgl. 4-part	
 39mm	 49mm	 56mm	
 38mm	 41mm	 39mm	



'BL' New Edge Granite Grinder

-  Aluminium, hart anodisiert | Hard Anodized
-  Anthrazit | Anthracite
-  'BL' Granite-Logo
-  4-tgl. | 4-part
-  Diamantschliff Zähne
Diamond-cut Teeth
-  Geschenkbox
Gift Box









43 02 103	43 02 104
 38mm	 50mm
 38mm	 41mm
43 02 105	43 02 106
 55mm	 63mm
 42mm	 45mm

'BL' Grinder

-  Aluminium
-  'BL'-Logo
-  2-tgl. | 2-part
-  Diamantschliff Zähne
Diamond-cut Teeth
-  Geschenkdose
Gift Box

- | | | |
|-------------|-------------|-------------|
| 43 02 20-27 | 43 02 27-27 | 43 02 28-27 |
| 43 02 20-28 | 43 02 27-28 | 43 02 28-28 |
| 43 02 20-29 | 43 02 27-29 | 43 02 28-29 |
| 43 02 20-30 | 43 02 27-30 | 43 02 28-30 |
| 43 02 20-33 | 43 02 27-33 | 43 02 28-33 |
| 43 02 20-35 | 43 02 27-35 | 43 02 28-35 |
| 43 02 20-36 | 43 02 27-36 | 43 02 28-36 |
| 43 02 20-37 | 43 02 27-37 | 43 02 28-37 |
| 43 02 20-39 | 43 02 27-39 | 43 02 28-39 |
| 43 02 20-40 | 43 02 27-40 | 43 02 28-40 |
| 43 02 20-46 | 43 02 27-46 | 43 02 28-46 |

- | | | |
|-------------------------------------------------------------------------------------------|----------------------------------------------------------------------------------------|----------------------------------------------------------------------------------------|
|  40mm |  50mm |  55mm |
|  16-20mm |  20mm |  17mm |



'BL' Grinder

-  Aluminium
-  'BL'-Logo
-  4-tgl. | 4-part
-  Diamantschliff Zähne
Diamond-cut Teeth
-  Geschenkdose
Gift Box





- | | |
|-------------|-------------|
| 43 02 19-27 | 43 02 68-27 |
| 43 02 19-28 | 43 02 68-28 |
| 43 02 19-29 | 43 02 68-29 |
| 43 02 19-30 | 43 02 68-30 |
| 43 02 19-33 | 43 02 68-33 |
| 43 02 19-35 | 43 02 68-35 |
| 43 02 19-36 | 43 02 68-36 |
| 43 02 19-37 | 43 02 68-37 |
| 43 02 19-39 | 43 02 68-39 |
| 43 02 19-40 | 43 02 68-40 |
| 43 02 19-46 | 43 02 68-46 |

- | | |
|--------------------------------------------------------------------------------------------|-----------------------------------------------------------------------------------------------|
|  40mm |  50mm |
|  35mm |  35-38mm |



- 43 02 10-27
- 43 02 10-28
- 43 02 10-29
- 43 02 10-30
- 43 02 10-33
- 43 02 10-35
- 43 02 10-36
- 43 02 10-37
- 43 02 10-39
- 43 02 10-40
- 43 02 10-41
- 43 02 10-46



- | |
|------------------------------------------------------------------------------------------|
|  55mm |
|  40mm |



'BL' Grinder

-  Aluminium
-  'BL'-Logo
-  4-tgl. | 4-part
-  Diamantschliff Zähne
Diamond-cut Teeth
-  Geschenkdose
Gift Box

- 43 01 08-28
- 43 01 08-29
- 43 01 08-30
- 43 01 08-35
- 43 01 08-36
- 43 01 08-37
- 43 01 08-39





- | |
|--------------------------------------------------------------------------------------------|
|  62mm |
|  40mm |

'BL' Grinder

-  Aluminium
-  'BL'-Logo
-  4-tgl. | 4-part
-  Diamantschliff Zähne
Diamond-cut Teeth





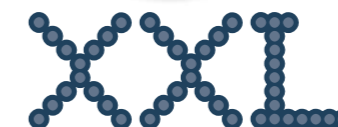

- | | |
|-------------|-------------|
| 43 02 78-33 | 43 02 79-33 |
| 43 02 78-35 | 43 02 79-35 |
| 43 02 78-36 | 43 02 79-36 |
| 43 02 78-39 | 43 02 79-39 |

- | | |
|--------------------------------------------------------------------------------------------|--------------------------------------------------------------------------------------------|
|  75mm |  90mm |
|  58mm |  70mm |



'BL' Grinder



-  Aluminium
-  'BL'-Logo
-  4-tgl. | 4-part
-  Diamantschliff Zähne
Diamond-cut Teeth

'BL' Riffel-Grinder
'BL' Ripple-Grinder





-  Aluminium
-  'BL'-Logo
-  2-tgl. | 2-part
-  Diamantschliff Zähne
Diamond-cut Teeth



- 43 01 20-27
- 43 01 20-28
- 43 01 20-29
- 43 01 20-30
- 43 01 20-33
- 43 01 20-35
- 43 01 20-36
- 43 01 20-37
- 43 01 20-39
- 43 01 20-40
- 43 01 20-46





-  50mm
-  20mm

'BL' Groove-Grinder

-  Aluminium
-  'BL'-Logo
-  4-tgl. | 4-part
-  Diamantschliff Zähne
Diamond-cut Teeth









- | | |
|-------------|-------------|
| 43 01 16-27 | 43 01 17-27 |
| 43 01 16-28 | 43 01 17-28 |
| 43 01 16-29 | 43 01 17-29 |
| 43 01 16-30 | 43 01 17-30 |
| 43 01 16-33 | 43 01 17-33 |
| 43 01 16-35 | 43 01 17-35 |
| 43 01 16-36 | 43 01 17-36 |
| 43 01 16-37 | 43 01 17-37 |
| 43 01 16-39 | 43 01 17-39 |
| 43 01 16-40 | 43 01 17-40 |
| 43 01 16-46 | 43 01 17-46 |

- | | |
|--------------------------------------------------------------------------------------------|--------------------------------------------------------------------------------------------|
|  40mm |  50mm |
|  34mm |  36mm |



- | | | |
|-------------|-------------|-------------|
| 43 02 96-28 | 43 02 97-28 | 43 02 99-28 |
| 43 02 96-29 | 43 02 97-29 | 43 02 99-29 |
| 43 02 96-31 | 43 02 97-31 | 43 02 99-31 |
| 43 02 96-33 | 43 02 97-33 | 43 02 99-33 |
| 43 02 96-35 | 43 02 97-35 | 43 02 99-35 |
| 43 02 96-36 | 43 02 97-36 | 43 02 99-36 |
| 43 02 96-37 | 43 02 97-37 | 43 02 99-37 |
| 43 02 96-38 | 43 02 97-38 | 43 02 99-38 |

- | | | |
|------------------------------------------------------------------------------------------|------------------------------------------------------------------------------------------|------------------------------------------------------------------------------------------|
|  38mm |  50mm |  55mm |
|  38mm |  40mm |  40mm |

'BL' Grinder 'New Edge'

-  Aluminium
-  'BL'-Logo
-  4-tgl. | 4-part
-  Diamantschliff Zähne
Diamond-cut Teeth



'BL' Grinder 'New Edge'











-  Aluminium
-  'BL'-Logo
-  5-tgl. | 5-part
-  50mm
-  53mm
-  Diamantschliff Zähne
Diamond-cut Teeth
-  Maschenweite Sieb 80µ+100µ
Mesh Width Screen 80µ+100µ





- 43 02 98-28
- 43 02 98-29
- 43 02 98-31
- 43 02 98-33
- 43 02 98-35
- 43 02 98-36
- 43 02 98-37
- 43 02 98-38

Something for the ladies!



- | | | |
|--------------|-------------|-------------|
| 43 02 127-34 | 43 02 94-34 | 43 02 95-34 |
| 43 02 127-35 | 43 02 94-35 | 43 02 95-35 |
| 43 02 127-39 | 43 02 94-36 | 43 02 95-36 |
-  2-tgl. | 2-part
 -  55mm
 -  29mm
 -  4-tgl. | 4-part
 -  55mm
 -  40mm
 -  Samtbeutel
Velvet Bag
 -  4-tgl. | 4-part
 -  62mm
 -  46mm
 -  Samtbeutel
Velvet Bag

'BL' Grinder 'Crown'

-  Aluminium
-  'BL'-Logo 'In Weed We Trust'
-  Trapezförmige Zähne
Trapezoid-shaped Teeth



'BL' Mini-Grinder







-  Aluminium
-  'BL'-Logo
-  Diamantschliff Zähne
Diamond-cut Teeth



- | | |
|--------------|--------------|
| 43 02 120-27 | 43 02 121-27 |
| 43 02 120-28 | 43 02 121-28 |
| 43 02 120-29 | 43 02 121-29 |
| 43 02 120-35 | 43 02 121-35 |
| 43 02 120-37 | 43 02 121-37 |
| 43 02 120-39 | 43 02 121-39 |

- | | |
|-------------------------------------------------------------------------------------------------------|-------------------------------------------------------------------------------------------------------|
|  2-tgl. 2-part |  4-tgl. 4-part |
|  29mm |  29mm |
|  20mm |  35mm |

'BL' Aluminium Grinder

-  Aluminium
-  'BL'-Logo 'In Weed We Trust'
-  4-tgl. | 4-part
-  62mm
-  37mm
-  Trapezförmige Zähne
Trapezoid-shaped Teeth

Prototyp | Prototype



'BL' Aluminium Grinder

-  Aluminium
-  'BL'-Logo
-  4-tgl. | 4-part
-  62mm
-  45mm
-  Rotorklingen
Rotor Blades
-  Geschenkbox
Gift Box



'BL' Aluminium Grinder Bajonettverschluss
'BL' Aluminium Grinder Bayonet Joint

-  Aluminium
-  'BL'-Logo
-  4-tgl. | 4-part
-  62mm
-  45mm
-  Blockzähne
Block Teeth
-  Geschenkbox
Gift Box
-  Bajonettverschluss
Bayonet Joint



'BL' Aluminium Grinder Mahlwerk mit Antihafbeschichtung
'BL' Aluminium Grinder with Non-stick Teeth

-  Aluminium
-  'BL'-Logo
-  4-tgl. | 4-part
-  62mm
-  45mm
-  Anti-haft Diamantschliff Zähne
Anti-stick Diamond-cut Teeth
-  Geschenkbox
Gift Box



DIAMANTSCHLIFF ZÄHNE MIT KERAMISCHER ANTIHAFTBESCHICHTUNG
DIAMOND-CUT TEETH WITH CERAMIC NON-STICK COATING

'BL' Fatty-Grinder

- Aluminium
- 'BL'-Logo Fatty
- 3-tgl. | 3-part
- Diamantschliff Zähne
Diamond-cut Teeth



43 02 124-35 43 02 124-39	43 02 125-35 43 02 125-39	43 02 126-35 43 02 126-39
39mm 45mm	50mm 46mm	56mm 43mm

XXL VORRATSFACH
XXL STORAGE CHAMBER

'BL' 'S&G' Shaker-Grinder

- Aluminium
- 'BL' Shaker & Grinder, S&G
- 5-tgl. | 5-part
- Diamantschliff Zähne
Diamond-cut Teeth
- Geschenkbbox
Gift Box



43 02 116-27 43 02 116-28 43 02 116-29 43 02 116-35 43 02 116-37 43 02 116-39	49mm 82mm
43 02 115-27 43 02 115-28 43 02 115-29 43 02 115-35 43 02 115-37 43 02 115-39	56mm 92mm

'BL' 'Hulk' Grinder

- Aluminium
- 'BL'-Logo HULK
- 4-tgl. | 4-part
- Blockzähne, Diamantschliff
Block Teeth, Diamond-cut

43 02 118-27 43 02 118-28 43 02 118-29 43 02 118-35 43 02 118-37 43 02 118-39	43 02 119-27 43 02 119-28 43 02 119-29 43 02 119-35 43 02 119-37 43 02 119-39
----------------------------------------------------------------------------------------------	----------------------------------------------------------------------------------------------

50mm 53mm	56mm 54mm
--------------	--------------

BLOCKMAHLWERK
BLOCK GRINDER



43 02 40
43 02 45



43 02 41
43 02 46

'BL' Grinder

- Aluminium
- 'BL'-Logo
- 2-tgl. | 2-part
- Diamantschliff Zähne
Diamond-cut Teeth
- Geschenkbbox
Gift Box

43 02 37
43 02 42

43 02 38
43 02 43

43 02 37 43 02 38 43 02 39 43 02 40 43 02 41	43 02 42 43 02 43 43 02 44 43 02 45 43 02 46
----------------------------------------------------------	----------------------------------------------------------

38mm 18mm	53mm 22mm
--------------	--------------

'BL' Grinder

- Aluminium
- 'BL'-Logo
- 4-tgl. | 4-part
- Diamantschliff Zähne
Diamond-cut Teeth



43 02 47 38mm 37mm	43 02 48 38mm 37mm	43 02 49 40mm 37mm	43 02 50 53mm 43mm	43 02 51 53mm 43mm
--------------------------	--------------------------	--------------------------	--------------------------	--------------------------

43 02 52 53mm 43mm	43 02 53 62mm 45mm
--------------------------	--------------------------





'BL' Stufen-Grinder
'BL' Stage Grinder



-  Aluminium
-  'BL'-Logo
-  4-tgl. | 4-part
-  Diamantschliff Zähne
Diamond-cut Teeth



43 02 84

-  50mm
-  40mm

43 02 85

-  55mm
-  40mm

43 02 80-36









43 02 80-35

43 02 80-39



'BL' Cross Grinder

-  Aluminium
-  'BL'-Logo
-  4-tgl. | 4-part
-  55mm
-  35mm
-  Diamantschliff Zähne
Diamond-cut Teeth

'BL' 'Startrails' Grinder Bajonettverschluss
'BL' 'Startrails' Grinder Bayonet Joint

-  Aluminium
-  'BL'-Startrails-Logo
-  4-tgl. | 4-part
-  Rotorklingen
Rotor Blades
-  Geschenkbox
Gift Box
-  Bajonettverschluss
Bayonet Joint

43 02 100-28
43 02 100-29
43 02 100-35
43 02 100-37
43 02 100-39

-  42mm
-  56mm





'BL' Grinder konkav | concave



-  Aluminium
-  'BL'-Logo
-  4-tgl. | 4-part
-  Diamantschliff Zähne
Diamond-cut Teeth
-  Konkav-Mahlwerk
Concave Grinder Chamber



43 02 101-35
43 02 101-39

-  40mm
-  51mm





43 02 102-35
43 02 102-39

-  50mm
-  48mm



KONKAV-MAHLWERK
CONCAVE GRINDER CHAMBER

'BL' 'Deep Engraving' Grinder

-  Aluminium, Zähne hart anodisiert, Edelstahlsieb
Aluminium, Teeth hard anodised, Stainless Steel Screen
-  'BL'-Logo
-  Diamantschliff Zähne
Diamond-cut Teeth
-  Geschenkbox
Gift Box



43 02 131

-  2-tgl. | 2-part
-  53mm
-  24mm

43 02 129

-  2-tgl. | 2-part
-  63mm
-  23mm

43 02 130

-  4-tgl. | 4-part
-  53mm
-  53mm

43 02 128



-  4-tgl. | 4-part
-  63mm
-  58mm

ZÄHNE HART ANODISIERT
TEETH HARD ANODISED

'BL' Rasta-Grinder

-  Aluminium
-  'BL'-Logo
-  4-tgl. | 4-part
-  Diamantschliff Zähne
Diamond-cut Teeth



43 02 134	43 02 135	43 02 136
 39mm	 49mm	 62mm
 37mm	 42mm	 48mm

'BL' Grinder mit Vibrationssieb 'BL' Grinder with vibrator

-  Aluminium
-  'BL' Premium-Logo
-  5-tgl. | 5-part
-  54mm
-  58mm
-  Diamantschliff Zähne
Diamond-cut Teeth
-  Mit batteriebetriebenen Vibrator
With battery-powered vibrator





43 29 01

'BL' Goblet-Grinder

-  Aluminium
-  'BL'-Logo Leaf
-  4-tgl. | 4-part
-  Diamantschliff Zähne
Diamond-cut Teeth



- 43 02 137-29
- 43 02 137-34
- 43 02 137-35
- 43 02 137-36
- 43 02 137-38
- 43 02 137-39

-  63mm
-  48mm

**BESONDERS GRIFFIG!
ESPECIALLY HANDY!**

'Black Leaf' Grinder

-  Aluminium
-  2-tgl. | 2-part
-  50mm
-  20mm
-  Diamantschliff Zähne
Diamond-cut Teeth



43 02 07-1  Leaf Skull	43 02 07-5  Ganesha	43 02 07-BL  Black Leaf	43 02 07-CT  Celtic
43 02 07-2  Mushroom	43 02 07-NBL  BL - In Weed We Trust	43 02 07-DEA  DEA	43 02 07-WE  Hanf I Weed
43 02 07-3  Mexican Skull	43 02 07-THC  THC	43 02 07-YY  Ying Yang	43 02 07-HE  Horus Eye
43 02 07-4  Cyber Skull	43 02 07-H  Haschisch	43 02 07-IW  In Weed We Trust	

43 02 07-1, 2, 3, 4, 5
Prototypen | Prototypes

'Black Leaf' Grinder

-  Aluminium
-  4-tgl. | 4-part
-  50mm
-  40mm
-  Diamantschliff Zähne
Diamond-cut Teeth



43 02 09-1  Leaf Skull	43 02 09-5  Ganesha	43 02 09-BL  Black Leaf
43 02 09-2  Mushroom	43 02 09-NBL  BL - In Weed We Trust	43 02 09-DEA  DEA
43 02 09-3  Mexican Skull	43 02 09-THC  THC	43 02 09-YY  Ying Yang
43 02 09-4  Cyber Skull	43 02 09-H  Haschisch	43 02 09-IW  In Weed We Trust
		43 02 09-CT  Celtic
		43 02 09-WE  Hanf I Weed
		43 02 09-HE  Horus Eye

43 02 09-1, 2, 3, 4, 5
Prototypen | Prototypes

'Solinder' 'After Grow' Grinder

-  Aluminium
-  'After Grow'
-  4-tgl. | 4-part
-  62mm
-  48mm
-  Wellen Zähne, Diamantschliff
Wave Teeth, Diamond-cut
-  Geschenkbox
Gift Box



'Thorinder' 'After Grow' Grinder

-  Aluminium
-  'Thorinder After Grow'
-  4-tgl. | 4-part
-  62mm
-  48mm
-  Diamantschliff Zähne
Diamond-cut Teeth
-  Geschenkbox
Gift Box



'Thorinder' 'After Grow' Mini-Grinder

-  Aluminium
-  'Thorinder After Grow'
-  4-tgl. | 4-part
-  50mm
-  42mm
-  Diamantschliff Zähne
Diamond-cut Teeth
-  Geschenkbox
Gift Box



'Kannastör' Grinder

- ★ Aluminium
- 👤 'KANNASTÖR'



43 02 138

- ⌀ 54mm
- 92mm



AMERICA'S TOP BRAND

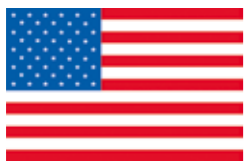

KANNASTÖR

43 02 139

- ⌀ 54mm
- 82mm



43 02 140

- ⌀ 54mm
- 54mm



'Kannastör' Clear Top-Grinder

- ★ Aluminium
- 👤 'KANNASTÖR'
- 📦 4-tgl. | 4-part
- 👉 Stoffbeutel
Cloth Bag



43 02 141

- ⌀ 54mm
- 57mm

43 02 142

- ⌀ 63mm
- 60mm



43 02 143

- ⌀ 54mm
- 67mm

43 02 144

- ⌀ 63mm
- 70mm

'Kannastör' Solid Top-Grinder

- ★ Aluminium
- 👤 'KANNASTÖR'
- 📦 4-tgl. | 4-part



43 02 145

- ⌀ 38mm
- 38mm

- 👉 Stoffbeutel
Cloth Bag

43 02 146

- ⌀ 54mm
- 57mm

- 👉 Stoffbeutel, Ersatzsieb aus
Edelstahl 60 Mesh
Cloth Bag, Spare Stainless
Steel Screen 60 Mesh

43 02 147

- ⌀ 63mm
- 57mm

- 👉 Stoffbeutel
Cloth Bag

43 02 148

- ⌀ 54mm
- 63mm

- 👉 Stoffbeutel, Ersatzsieb aus
Edelstahl 60 Mesh
Cloth Bag, Spare Stainless
Steel Screen 60 Mesh

43 02 149

- ⌀ 63mm
- 63mm

- 👉 Stoffbeutel, Ersatzsieb aus
Edelstahl 60 Mesh
Cloth Bag, Spare Stainless
Steel Screen 60 Mesh



'Kannastör' Black-Grinder

-  Aluminium
-  'KANNASTÖR'
-  4-tgl. | 4-part
-  Stoffbeutel, Ersatzsieb aus Edelstahl 60 Mesh
Cloth Bag, Spare Stainless Steel Screen 60 Mesh



43 02 157

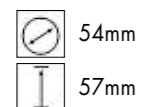

43 02 158

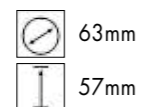

43 02 159

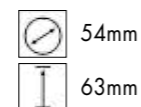

43 02 160



'Kannastör' Clear Top-Grinder

-  Aluminium
-  'KANNASTÖR'
-  2-tgl. | 2-part
-  Stoffbeutel
Cloth Bag

43 02 150

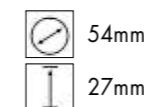

43 02 151

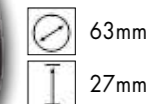

'Kannastör' Solid Top-Grinder

-  Aluminium
-  'KANNASTÖR'
-  2-tgl. | 2-part
-  Stoffbeutel
Cloth Bag

43 02 152

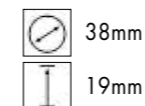

43 02 153

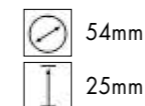

43 02 154

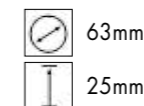

AMERICA'S TOP BRAND



'Kannastör' 'Easy Change Screen' Edelstahlsieb 'Kannastör' 'Easy Change Screen' Stainless Steel



50 10 04

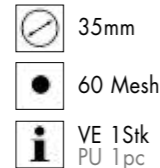

50 10 05

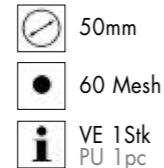

50 10 06

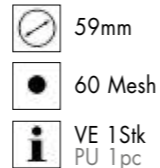

'Kannastör' 'Störage Puck' Vorratsdose 'Kannastör' 'Störage Puck'



-  Aluminium
-  'KANNASTÖR'
-  2-tgl. | 2-part
-  Stoffbeutel
Cloth Bag

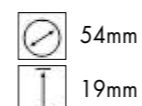

36 02 04



'Kannastör' Pendant-Grinder

-  Aluminium
-  'KANNASTÖR'
-  2-tgl. | 2-part
-  Kugel-Halskette, Stoffbeutel
Ball chain necklace, Cloth Bag

43 02 155

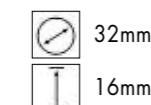

'Kannastör' Presser

- Aluminium
- 'KANNASTÖR'



AMERICA'S TOP BRAND

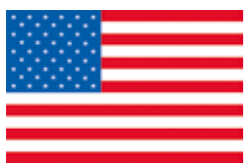

50 02 12
14/22mm
60mm

50 02 13
19/25mm
60mm

'RYOT' Raucher Werkzeug
'RYOT' Utility Tool

- Edelstahl-Konstruktion
Stainless Steel Construction
- 'RYOT'
- Silikon-Schutzhülle
Silicone Protective Covering



55 05 02

RYOT | UTILITY TOOL



- Silikonschaufel
Silicone Scoop
- Konzentratgabel
Concentrate Fork
- Gebogene Schaufel
Curved Scoop
- Klinge zum Säubern
Cleaning Blade
- Reibe
Grinder
- Flaschenöffner & Flacher
Schraubenzieher
Bottle Opener & Flat Head Driver
- Haken
Detail Hook
- Stoher
Poker
- Flache Schaufel
Flat Scoop
- Stopfer
Tampor

'ANAXY' Alu-Grinder/Dosierer | Dispenser

- Aluminium
- 9-tgl. | 9-part
- 54mm
- 90mm
- Diamantschliff Zähne
Diamond-cut Teeth
- Geschenkbox, Pipe
Gift Box, Pipe

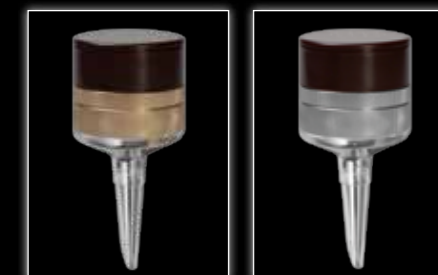

43 02 123-27

43 02 123-39



ANAXY

'Anaxy' 'Seed' Grinder





- Aluminium, Kunststoff
Aluminium, Plastic
- 2-tgl. | 2-part
- 55mm
- 65mm
- Trapezzähne, Diamantschliff
Trapezoid Teeth, Diamond-cut



43 02 161-27

43 02 161-36

'TARGET' Grinder

-  Aluminium
-  Silber/Schwarz | Silver/Black
-  'TARGET'-Logo
-  Diamantschliff Zähne | Diamond-cut Teeth
-  Geschenkbox
Gift box



ZMT 010

-  2-tgl. | 2-part
-  53mm
-  26mm

ZMT 030

-  2-tgl. | 2-part
-  63mm
-  31mm



ZMT 020

-  4-tgl. | 4-part
-  53mm
-  53mm

ZMT 040

-  4-tgl. | 4-part
-  63mm
-  63mm



ZMT 050

-  4-tgl. | 4-part
-  63mm
-  60mm

'Mind' Aluminium Grinder

-  Aluminium
-  'Mind' Grinder
-  4-tgl. | 4-part
-  55mm
-  67mm
-  Diamantschliff Zähne
Diamond-cut Teeth
-  Ersatzzähne, Geschenkbox
Spare Teeth, Gift Box

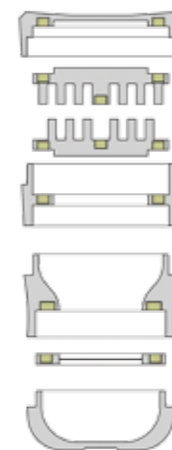

Sieb und Zähne magnetisch haltend
Removable Magnetic Screen and Teeth



43 02 174

Prototyp | Prototype





Metallgrinder gerillt grau/silber Rippled Metal Grinder grey



-  Aluminium
-  Neutral, ohne Logo
Neutral, without Logo
-  4-tgl. | 4-part
-  Diamantschliff Zähne
Diamond-cut Teeth



43 01 18

-  55mm
-  40mm

43 01 19



-  62mm
-  40mm

Alu-Grinder



-  Aluminium
-  Neutral, ohne Logo
Neutral, without Logo
-  2-tgl. | 2-part
-  Diamantschliff Zähne
Diamond-cut Teeth



43 02 01-35



-  56mm
-  21mm

43 02 02-35



-  44mm
-  21mm

 B-Ware mit Kratzern.
Keine Reklamation möglich!
B-Stock with dents in the casing!
No claims possible!

43 02 01-39

-  56mm
-  21mm

43 02 02-39

-  44mm
-  21mm

'Mill' Aluminium Fenster Grinder
'Mill' Aluminium Window Grinder

-  Aluminium
-  Neutral, ohne Logo
Neutral, without Logo
-  4-tgl. | 4-part
-  62mm
-  47mm
-  Rotorklingen, Diamantschliff
Rotor Blades, Diamond-cut



43 02 175

 schwarz/gold
black/gold

'Propeller' Aluminium Grinder

-  Aluminium
-  Neutral, ohne Logo
Neutral, without Logo
-  4-tgl. | 4-part
-  62mm
-  44mm
-  Propeller



43 02 176-35

 schwarz/silber/bronze
black/silver/bronze

43 02 176-39

 silber/bronze
silver/bronze

'Skill Game' Aluminium Fenster-Grinder
'Skill Game' Aluminium Window Grinder

-  Aluminium
-  Neutral, ohne Logo
Neutral, without Logo
-  4-tgl. | 4-part
-  63mm
-  55mm
-  Diamantschliff Zähne
Diamond-cut Teeth



Mit Geschicklichkeitsspiel Kugellabyrinth
With Skill Game Labyrinth

43 02 166

Fenster-Grinder mit Propeller
Window Grinder with Screw

-  Aluminium
-  Neutral, ohne Logo
Neutral, without Logo
-  4-tgl. | 4-part
-  63mm
-  48mm
-  Diamantschliff Zähne
Diamond-cut Teeth



99 02 01-35

99 02 01-28

'Diabolo' Aluminium Grinder

-  Aluminium
-  Neutral, ohne Logo
Neutral, without Logo
-  4-tgl. | 4-part
-  58mm
-  64mm
-  Diamantschliff Zähne
Diamond-cut Teeth



43 02 162-35

43 02 162-36

Grinder mit Auswurf
Grinder with Ejection

-  Metall | Metal
-  Neutral, ohne Logo
Neutral, without Logo
-  4-tgl. | 4-part
-  63mm
-  67mm
-  Diamantschliff Zähne
Diamond-cut Teeth
-  Mit Auswurf Funktion
With Ejection Function



43 04 06

Grinder & Presser Grinder & Pollen Presser

-  Metall | Metal
-  Neutral, ohne Logo
Neutral, without Logo
-  4-tgl. | 4-part
-  63mm
-  40mm
-  Diamantschliff Zähne
Diamond-cut Teeth
-  Geschenkbox
Gift Box





43 04 01



ZM 190

Alu-Grinder

-  Aluminium
-  Neutral, ohne Logo
Neutral, without Logo
-  2-tgl. | 2-part
-  60mm
-  20mm
-  Pyramiden
Pyramid shaped



Grinder konkav Grinder concave

-  Metall | Metal
-  Neutral, ohne Logo
Neutral, without Logo
-  4-tgl. | 4-part
-  Diamantschliff Zähne
Diamond-cut Teeth
-  Deckel / Mahlfach konkav geformt
Lid / Grinding Chamber concave formed

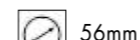
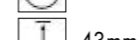

43 04 09

-  63mm
-  43mm

43 04 08

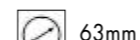
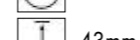
-  63mm
-  43mm

'Masher' Aluminium Grinder

-  Aluminium
-  Neutral, ohne Logo
Neutral, without Logo
-  4-tgl. | 4-part
-  53mm
-  52mm
-  Masher



43 02 168-27

43 02 168-34

43 02 168-29

43 02 168-39

43 02 168-33

43 02 168-37

43 02 168-35



'Masher' Aluminium Grinder

-  Aluminium
-  Neutral, ohne Logo
Neutral, without Logo
-  4-tgl. | 4-part
-  63mm
-  52mm
-  Masher



43 02 167-27

43 02 167-33

43 02 167-29





43 02 167-34

43 02 167-37

43 02 167-35







43 02 167-39

Grinder

-  Aluminium
-  Neutral, ohne Logo
Neutral, without Logo
-  4-tgl. | 4-part
-  Diamantschliff Zähne
Diamond-cut Teeth



- | | | |
|-------------|-------------|-------------|
| 43 02 61-28 | 43 02 60-28 | 43 02 64-28 |
| 43 02 61-29 | 43 02 60-29 | 43 02 64-29 |
| 43 02 61-31 | 43 02 60-33 | 43 02 64-31 |
| 43 02 61-33 | 43 02 60-34 | 43 02 64-34 |
| 43 02 61-34 | 43 02 60-35 | 43 02 64-35 |
| 43 02 61-35 | 43 02 60-36 | 43 02 64-36 |
| 43 02 61-36 | 43 02 60-37 | 43 02 64-37 |
| 43 02 61-37 | 43 02 60-39 | 43 02 64-39 |
| 43 02 61-39 | 43 02 60-43 | 43 02 64-43 |

- | | | |
|-----------------------------------------------------------------------------------------|-----------------------------------------------------------------------------------------|-----------------------------------------------------------------------------------------|
|  40mm |  50mm |  56mm |
|  36mm |  40mm |  40mm |



43 02 83-35

43 02 83-36

43 02 83-29

43 02 83-43

'Heavy Duty' Grinder

-  Aluminium
-  Neutral, ohne Logo
Neutral, without Logo
-  4-tgl. | 4-part
-  60-62mm
-  45mm
-  Blockzähne, Diamantschliff
Block Teeth, Diamond-cut

Elektro Grinder Elektric Grinder

-  Aluminium
-  Neutral, ohne Logo
Neutral, without Logo
-  145mm
-  Batterie betriebener Grinder
Batterie operated Grinder



43 29 00

Multifunktionaler Grinder mit Trichter Multifunctional Grinder with Funnel

-  Aluminium, Acryl
Aluminium, Acrylic
-  Neutral, ohne Logo
Neutral, without Logo
-  3-tgl. | 3-part
-  56mm
-  90mm
-  Diamantschliff Zähne
Diamond-cut Teeth
-  VE 6Stk im Display
PU 6pcs in a Display



43 04 05

Alu-Grinder mit Grob- und Feinsieb Alu Grinder with coarse and fine screen

-  Aluminium
-  Neutral, ohne Logo
Neutral, without Logo
-  5-tgl. | 5-part
-  50mm
-  53mm
-  Diamantschliff Zähne
Diamond-cut Teeth



43 02 67-31

43 02 67-36

43 02 67-29

43 02 67-35

43 02 67-39

43 02 67-37

43 02 67-41

Fenster-Grinder Window Grinder

-  Aluminium
-  Neutral, ohne Logo
Neutral, without Logo
-  2-tgl. | 2-part
-  50mm
-  24mm
-  Diamantschliff Zähne
Diamond-cut Teeth



Fenster-Grinder Window Grinder

-  Aluminium
-  Neutral, ohne Logo
Neutral, without Logo
-  4-tgl. | 4-part
-  50mm
-  44mm
-  Diamantschliff Zähne
Diamond-cut Teeth









Kurbel-Grinder Crank Grinder

-  Aluminium
-  Neutral, ohne Logo
Neutral, without Logo
-  4-tgl. | 4-part
-  60-63mm
-  45-50mm
-  Diamantschliff Zähne
Diamond-cut Teeth



'Blitz' Alu-Fenster-Kurbelgrinder 'Blitz' Aluminium Window Crank Grinder

-  Aluminium
-  Neutral, ohne Logo
Neutral, without Logo
-  4-tgl. | 4-part
-  62mm
-  72mm
-  Wellenzähne, Diamantschliff
Wave Teeth, Diamond-cut



99 02 06
 schwarz/bronze/silber
black/bronze/silver

'Blitz' Alu-Fenster-Kurbelgrinder 'Blitz' Aluminium Window Crank Grinder

-  Aluminium
-  Neutral, ohne Logo
Neutral, without Logo
-  4-tgl. | 4-part
-  63mm
-  59mm
-  Wellenzähne, Diamantschliff
Wave Teeth, Diamond-cut



99 02 07-35
 schwarz/schwarz
black/black

99 02 07-37
 schwarz/grün
black/green

99 02 07-39
 schwarz/silber
black/silver

Push-up Grinder

-  Aluminium, Acryl
-  Neutral, ohne Logo
Neutral, without Logo
-  2-tgl. | 2-part
-  40mm
-  26mm
-  Diamantschliff Zähne
Diamond-cut Teeth
-  Praktische Auswurf-Funktion durch
verschiebbaren Boden!
Practical Ejection Function due to Slide lid!



43 01 23-28

43 01 23-37

43 01 23-39





43 01 23-29





43 01 23-35

Metall Grinder gerillt Ölfarben Rippled Metal Grinder Oil Colours

-  Metall
Metal
-  Neutral, ohne Logo
Neutral, without Logo
-  4-tgl. | 4-part
-  Diamantschliff Zähne
Diamond-cut Teeth



- | | |
|------------------------------------------------------------------------------------------|------------------------------------------------------------------------------------------|
| 43 04 11 | 43 04 12 |
|  40mm |  50mm |
|  43mm |  43mm |

- | | |
|------------------------------------------------------------------------------------------|------------------------------------------------------------------------------------------|
| 43 04 13 | 43 04 14 |
|  55mm |  63mm |
|  43mm |  44mm |

Grinder Ölfarben Grinder Oil Colours

-  Metall | Metal
-  Neutral, ohne Logo
Neutral, without Logo
-  4-tgl. | 4-part
-  58mm
-  43mm
-  Diamantschliff Zähne
Diamond-cut Teeth



43 04 07

Grinder

-  Aluminium
-  Neutral, ohne Logo
Neutral, without Logo
-  4-tgl. | 4-part
-  49mm
-  42mm
-  Diamantschliff Zähne
Diamond-cut Teeth



43 01 22-61

43 01 22-1

43 01 22-2

43 01 22-3

43 01 22-1

-  Leafs

43 01 22-2

-  Skulls 1

43 01 22-3

-  Skulls 2

43 01 22-61

-  Leafs, Skulls 1, Skulls 2

 VE 12Stk im Display
 PU 12pcs in a Display
 Keine Motivwahl möglich!
 Choice of design not possible!

HOLZMÜHLEN WOODEN GRINDER GRINDER IN LEGNO GRINDER EN BOIS GRINDER DE MADERA

Mühlen aus Holz, aus nachwachsendem, abgelagertem, spannungs-
 freiem Holz. Sie sind von Hand geschnitzt und haben eine angenehme
 Haptik. Das verwendete Hartholz stammt meist aus Plantagenanbau.

Wooden Grinders, made of renewable, seasoned, tension-free
 wood are hand-carved and have pleasant haptics. The hard wood
 used comes mostly from plantation cultivation.

I grinder in legno sono realizzati in legno rinnovabile, stagionato e
 resistente alla tensione. Sono intagliati a mano e piacevoli al tatto.
 Il legno duro utilizzato proviene per la maggior parte da piantagioni.

Moulins en bois, en bois naturel sec et résistant à la tension. Ils sont
 sculptés à la main et agréables au toucher. Le bois dur utilisé provient
 généralement de plantations.

Los grinders de madera están hechos de una madera renovable,
 curada y sin tensión. Están tallados a mano y tienen un tacto agradable.
 La madera dura utilizada viene de plantaciones.

Rosenholz-Mühlen
Rosewood Grinder

-  Rosenholz | Rosewood
-  2-tgl. | 2-part
-  20-49mm
-  Stifte | Pin Teeth

43 07 01
 Hanfblatt I Leaf
 55mm

43 07 04
 glatt I smooth
 55mm

43 07 07
 Hanfblatt I Leaf
 55mm

43 07 05
 glatt I smooth
 55mm

43 07 08S
 OM aus Stein
Stone inlay OM
 45mm

43 07 08
 OM aus Stein
Stone inlay OM
 55mm

43 07 40
 Blatt I Leaf
 50mm

43 07 15
 glatt I smooth
 51mm

43 07 03
 Hanfblatt I Leaf
 75mm

43 07 09S
 Hanfblatt aus Stein
Stone inlay Leaf
 40mm

43 07 09
 Hanfblatt aus Stein
Stone inlay Leaf
 55mm

43 07 10
 Ying Yang aus Stein
Stone inlay Ying Yang
 45mm

43 07 16
 Hanfblatt I Leaf
 56mm

43 07 42M
 Buddha
 60mm

43 07 41L
 Kobra I Cobra
 75mm

43 07 41S
 Kobra I Cobra
 50mm

43 07 41M
 Kobra I Cobra
 60mm

43 07 42L
 Buddha
 75mm

43 07 42S
 Buddha
 50mm

43 07 20
 glatt I smooth
 40mm

43 07 21
 Hanfblatt I Leaf
 40mm

43 07 22
 Hanfblatt I Leaf
 40mm

43 07 24
 Hanfblatt I Leaf
 45mm

43 07 25
 glatt I smooth
 45mm

43 07 26
 Hanfblatt I Leaf
 45mm

43 07 27
 Hanfblatt I Leaf
 36mm

43 07 28
 glatt I smooth
 33mm

43 07 29
 Hanfblatt I Leaf
 33mm

43 07 30
 glatt I smooth
 33mm

43 07 31
 Blatt I Leaf
 33mm

43 07 32
 Hanfblatt aus Stein
Stone inlay Leaf
 35mm

43 07 33
 OM aus Stein
Stone inlay Om
 35mm

43 07 35
 glatt I smooth
 35mm

43 07 34
 YingYang
 35mm

43 07 36
 Hanfblatt I Leaf
 35mm

Rosenholz Rosewood Legno di rosa Bois de rose Madera de rosa

Alu/Rosenholz-Mühlen Alu/Rosewood Grinder

- Rosenholz | Rosewood
- Hanfblatt | Leaf
- Diamantförmige Zähne
Diamond-shaped Teeth



- | | | |
|----------------------------------------------------|----------------------------------------------------|----------------------------------------------------|
| 43 35 03
4-tgl. 4-part
44mm
52mm | 43 35 02
4-tgl. 4-part
50mm
56mm | 43 35 01
4-tgl. 4-part
56mm
59mm |
|----------------------------------------------------|----------------------------------------------------|----------------------------------------------------|



- 43 35 08**
2-tgl. | 2-part
49mm
49mm



- 43 35 06**
2-tgl. | 2-part
38mm
30mm



- 43 35 05**
2-tgl. | 2-part
45mm
28mm

- 43 35 04**
2-tgl. | 2-part
54mm
33mm



- 43 35 07**
2-tgl. | 2-part
54mm
34mm

Shishamholz-Mühlen Shishamwood Grinder

- Shishamholz | Shishamwood
- 2-tgl. | 2-part
- 30-35mm
- Stifte | Pin Teeth



- 43 07 11**
Buddha
55mm



- 43 07 12**
Elephant
51mm



- 43 07 17**
Floral
55mm



- 43 07 13**
Hanfblatt | Leaf
58mm



- 43 07 18**
Schlange | Snake
55mm

Holzmühlen Hardwood Grinder

- Holz | Wood
- 2-tgl. | 2-part
- 30-33mm
- Stifte | Pin Teeth

- ZM 199**
glatt | smooth
100mm



- ZM 196**
glatt | smooth
60mm



- ZM 179**
glatt | smooth
75mm



- ZM 195**
glatt | smooth
55mm

Buchenholz-Mühlen Beechwood Grinder

- Buchenholz | Beechwood
- Canamix
- 2-tgl. | 2-part
- 27-30mm
- Stifte | Pin Teeth



- CMIX 1**
52mm

- CMIX 2**
66mm



- CMIX 3**
78mm



- CMIX 4**
93mm



'Canamix' Mühle Buchenholz Holzstifte 'Canamix' Grinder Ash with Beechwood Pins

- Esche, Buchenholzstifte
Ash, Beechwood Pins
- Canamix
- 2-tgl. | 2-part
- 77mm
- 28mm
- Stifte
Pins



- 43 07 43**

canamix



Made in Germany

'Canamix' Mühle Esche mit Metallstiften magnetisch 'Canamix' Grinder Ash Wood with Metal Pins

- Eschenholz, Edelstahlstifte
Ash Wood, Stainless Steel Pins
- Canamix
- 2-tgl. | 2-part
- Stifte
Pins



- 43 07 46**
52mm
28mm

- 43 07 45**
67mm
28mm

- 43 07 44**
79mm
28mm

STEINMÜHLEN STONE GRINDER GRINDER IN PIETRA GRINDER EN PIERRE GRINDER DE PIEDRA

Speckstein-Mühlen Soapstone Grinder

 Speckstein | Soapstone

 2-tgl. | 2-part



 25-30mm

 Stifte | Pin Teeth

Bei einem Naturprodukt wie Speckstein fallen Farben und Muster immer unterschiedlich aus. Keine Farbwahl möglich.
Soapstone is a nature product. So colour can vary.





43 16 01

 OM
 45mm



43 16 00

 Ying-Yang
 45mm



43 16 02

 Hanfblatt | Leaf
 45mm

43 16 03

 glatt | smooth
 45mm



43 16 04

 glatt | smooth
 50mm



43 16 05

 Hanfblatt | Leaf
 50mm

ACRYLMÜHLEN ACRYLIC GRINDER GRINDER IN MATERIALE ACRILICO GRINDER EN ACRYLIQUE GRINDER DE ACRÍLICO

Mühlen aus Kunststoff sind extrem belastbar und beinahe verschleißfrei. Eine einfache und preiswerte Alternative.

Plastic Grinders are extremely resilient and almost wear-free. A simple and inexpensive alternative.

I grinder in plastica sono estremamente robusti e praticamente esenti da usura. Un'alternativa semplice e conveniente.

Les moulins en matière plastique sont extrêmement résistants et pratiquement sans usure. Une alternative simple et bon marché.

Los grinders de acrílico son extremadamente duraderos y casi sin desgaste. Una alternativa simple y barata.

Acrylmühle Acrylic Grinder

-  Kunststoff | Plastic
-  Neutral, ohne Logo
Neutral, without Logo
-  2-tgl. | 2-part
-  57mm
-  25mm
-  Diamantschliff Zähne
Diamond-cut Teeth

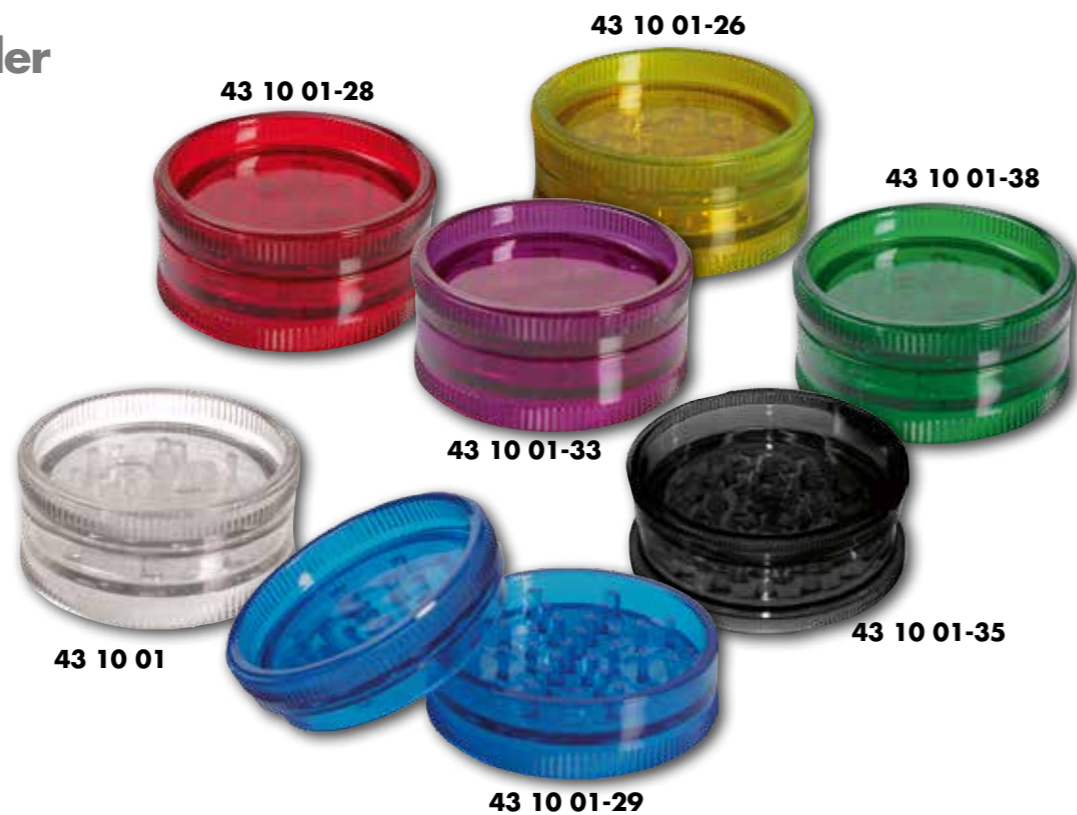

Acrylmühle Acrylic Grinder

-  Acryl | Acrylic
-  Neutral, ohne Logo/'BL'-Logo
Neutral, without Logo/'BL'-Logo
-  3-tgl. | 3-part
-  60mm
-  25mm
-  Pyramidenförmige Zähne
Pyramid-shaped Teeth



GRINDER MIT EIGENEM MOTIV?

**Kein Problem! Senden Sie
uns Ihr Logo, den Rest
machen wir!**

**Wir fertigen Ihnen Grinder mit Ihrem
Logo oder Ihrer Werbung ab 100Stk. pro
Logo an!**

Qualitäts Grinder aus bruchfestem Kunststoff,
3teilig, Ø60mm H 25mm, klar und ungefärbt,
mit Magnet und Vorratsfach, einzeln verpackt.

Ihr Logo oder Ihre Werbebotschaft werden im
Vorratsfach, unter dem Deckel, angebracht.

Wir benötigen dazu: Ihre Logo oder Ihre Vorlage
als PDF oder Adobe Illustrator Datei mit mindes-
tens 300dpi Auflösung. Der Durchmesser des
Logos oder der Werbung beträgt im Original
genau 50mm. Wir senden Ihnen vor Ausführung
des Auftrages ein Bild des Grinder zu, wie er
später aussehen wird.

Bitte senden Sie ihre Anfrage an:
grinder-promo@neardark.de

PROMO



PROMOTIONAL GRINDERS, WITH YOUR OWN LOGO OR MESSAGE?

**No problem! You supply
your logo or promotional
graphic, we do everything
else!**

**For a minimum order of 100pcs per
Logo, we will produce your own Acrylic
Promotional Grinders with your own
brand, logo or message!**

Quality 3 piece transparent grinders, made of
unbreakable plastic; Ø60mm, Height 25mm,
with magnetic fastener and stash compartment.
Each individually packed.

Your logo or promotion message will be 50mm
in diameter and will be fixed under the lid, in
the stash compartment.

We need: your logo or message as a PDF or
Adobe Illustrator file with minimum 300dpi
resolution. Before for-filling your order, we will
send you a draft picture by e-mail, of how your
grinder will look.

Please send your query to:
grinder-promo@neardark.de

Acrylmühle Acrylic Grinder

-  Kunststoff | Plastic
-  Neutral, ohne Logo
Neutral, without Logo
-  5-tgl. | 5-part
-  60mm
-  60mm
-  Pyramidenförmige Zähne
Pyramid-shaped Teeth
-  Keine Farbauswahl möglich
No colorchoice possible









43 10 03



43 10 05

Plastikmühle Plastic Grinder

-  Plastik | Plastic
-  Neutral, ohne Logo
Neutral, without Logo
-  2-tgl. | 2-part
-  54mm
-  24mm
-  Pyramidenförmige Zähne
Pyramid-shaped Teeth
-  VE 12Stk im Display
PU 12pcs in a Display



Hexa-Grinder

-  Kunststoff | Plastic
-  Neutral, ohne Logo
Neutral, without Logo
-  2-tgl. | 2-part
-  75mm
-  28mm
-  Pyramidenförmige Zähne
Pyramid-shaped Teeth

43 11 03-28

43 11 03-00

43 11 03-38



43 11 03-29



43 11 04

Alu-Acrylmühle Aluminum-Acrylic Grinder

-  Acryl, Aluminium | Acrylic, Aluminum
-  Neutral, ohne Logo
Neutral, without Logo
-  4-tgl. | 4-part
-  55mm
-  44mm
-  Pyramidenförmige Zähne
Pyramid-shaped Teeth
-  Keine Farbauswahl möglich
No colorchoice possible



Rasta-Grinder



-  Kunststoff | Plastic
-  Neutral, ohne Logo
Neutral, without Logo
-  3-tgl. | 3-part
-  Pyramidenförmige Zähne
Pyramid-shaped Teeth



43 11 01

43 11 02

-  42mm
-  22mm

-  60mm
-  27mm

'Greengo' Grinder

-  Recycelter Kunststoff | Recycled plastic
-  'Greengo'-Logo
-  3-tgl. | 3-part
-  50mm
-  25mm
-  Pyramidenförmige Zähne
Pyramid-shaped Teeth
-  VE 16Stk im Display
PU 16pcs in a Display



43 10 07

43 10 08



'grow!' Grinder

-  Kunststoff | Plastic
-  'grow!'-Logo
-  3-tgl. | 3-part
-  60mm
-  25mm
-  Pyramidenförmige Zähne
Pyramid-shaped Teeth



GROW 01

GROW 01A

MESSER UND ZUBEHÖR KNIVES AND ACCESSORIES COLTELLI E ACCESSORI COUTEAUX ET ACCESSOIRES CUCHILLOS Y ACCESORIOS

Messer und Bretter, das sind die traditionellen Geräte zur Zerkleinerung von Kraut und vor allem Harz. Für sehr große Mischungen sind sie den Grindern klar überlegen, zudem kann der Feinheitsgrad genauer bestimmt werden.

Knives and boards are the traditional tools for mincing herbs and especially resin. For major mixtures, they are clearly superior to grinders. Additionally, the degree of fineness can be defined more accurately.

Coltelli e taglieri sono gli utensili tradizionali usati per sminuzzare le erbe e soprattutto la resina. I grinder sono la soluzione ideale per grandi quantità di miscele, inoltre permettono di determinare con precisione la finezza di macinatura.

Couteaux et planches sont les outils traditionnels utilisés pour le hachage d'herbe et de résine, en particulier. Les grinders sont de loin la solution idéale pour de très gros mélanges, sans compter qu'ils permettent de déterminer plus précisément le degré de finesse.

Cuchillos y tablas, estos son los utensilios tradicionales para la trituración de hierba y, en especial, de resina. Para mezclas muy grandes, las tablas son claramente superiores a los grinders, y también el grado de finura se puede determinar con mayor precisión.

Hemp Cutter

- ★ Edelstahl | Stainless Steel
- 👤 Hemp Cutter
- 📏 Rosffrei | stainless



- ZM 270**
150mm
- ZM 271**
192mm

Weedboard mit Wiegemesser Weedboard with chopping knife

- ★ Eiche, Klinge aus Edelstahl
Blade made of stainless Steel
- 👤 Black Leaf
- 📏 200x200x25mm

- ZM 278B**
inkl. Pokernadel/Kratzwerkzeug
incl. poker needle



ZM 278

Weedboard mit Schublade und Wiegemesser | Weedboard with drawer and chopping knife

- ★ Holz, Metall
Wood, metal
- 👤 Black Leaf
- 📏 176x160x60mm



ZM 283

Wiegemesser Curved Chopping knife

- ★ Metall, Holz
Metal, wood
- 👤 Black Leaf
- 📏 160x110x25mm



ZM 280

'Black Leaf' Reinigungsnadel mit Hanfblatt | 'Black Leaf' Steel Needle with Hemp Leaf

- ★ Edelstahl | Stainless Steel
- 📏 83mm



50 04 14

'Black Leaf' Reinigungsnadel Set 'Black Leaf' Steel Needle Set

- ★ Stahl | Steel
- 📏 70mm
- 👤 Acryldisplay
Acrylic display
- 📏 VE 4x10Stk
PU 4x10pcs



50 04 21SET

Kunststoffschaber für Mühlen Plastic Scraper for Grinders

- ★ Kunststoff
Plastic
- 📏 28mm
- 📏 VE 100Stk
PU 100pcs



50 10 09

Gleitringe für Grinder Rubber Rings for Grinders

- ★ Nylon
- 👤 Weiß | White

- 17 23 00-40 (40mm-Grinder)**
40mm
- 17 23 00-50 (50mm-Grinder)**
50mm
- 17 23 00-55 (55mm-Grinder)**
55mm
- 17 23 00-62 (62mm-Grinder)**
62mm

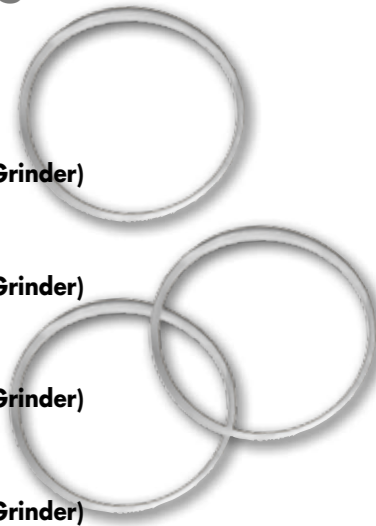

'Black Leaf' Grinderreiniger 'Black Leaf' Grinder Cleaner

- 📏 VE 1x50ml
PU 1x50ml



12 24 04



Kunststoffschaber für Mühlen Plastic Scraper for Grinders

- ★ Kunststoff
Plastic
- 📏 25x18mm
- 📏 VE 25Stk
PU 25pcs



50 10 11

'Black Leaf' Rolling Tray

-  Metall | Metal
-  Black Leaf Logo



- 55 04 15**
- In Weed We Trust
 - 180x140x16mm

- 55 04 19**
- In Weed We Trust
 - 275x175x25mm

- 55 04 22**
- In Weed We Trust
 - 340x275x27mm



- 55 04 17**
- Ganesha
 - 180x140x16mm

- 55 04 21**
- Ganesha
 - 275x175x25mm

- 55 04 24**
- Ganesha
 - 340x275x27mm



- 55 04 16**
- Mushroom
 - 180x140x16mm

- 55 04 20**
- Mushroom
 - 275x175x25mm

- 55 04 23**
- Mushroom
 - 340x275x27mm



- 55 04 18**
- Hanf
 - 180x140x16mm

GLASS
BLAZE®



Near Dark GmbH
Bonner Str. 11a
53773 Hennef, Germany

info@neardark.de

© Copyright 2018 Near Dark GmbH

Zentrale | Telephone Exchange:
+49 (0) 2242-8 74 16 -0

Bestellhotline | Order Hotline:
+49 (0) 2242-8 74 16 -24

Kundenservicehotline | Customer Service Hotline:
+49 (0) 2242-8 74 16 -25

www.neardark.de